

ARCHITECTURAL WINCH Model AW wire rope cable hand winch

The perfect hand winch for architectural applications and many consumer, residential, retail and light commercial uses. These small winches are used for chandeliers, blinds and shutters, clothes lines, awnings and flagpoles. Excellent in the garage for positioning and storing car-top cargo carriers and ski boxes, as well as canoes and kayaks onto your car or van roof rack.

Standard features include:

- Die-cast aluminum construction
- Powder coated surface finish
- Corrosion resistant internal parts
- Totally enclosed casing
- Self-locking load pressure brake
- Maintenance free
- Quiet and smooth operation
- Low cranking force
- Removable hand crank for tamper-proofing



AW 45

AW 100

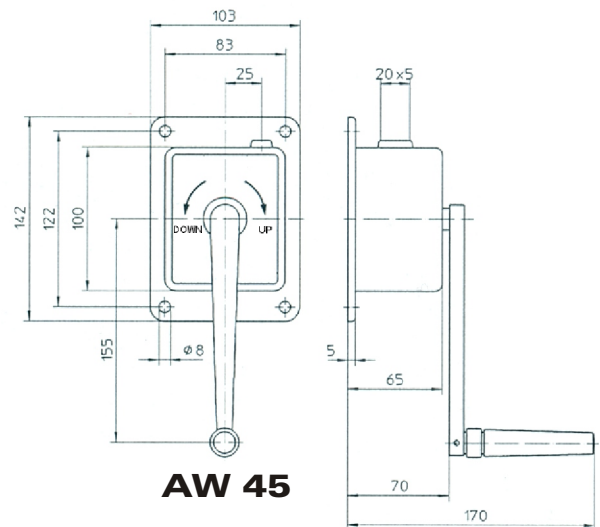

AW 45

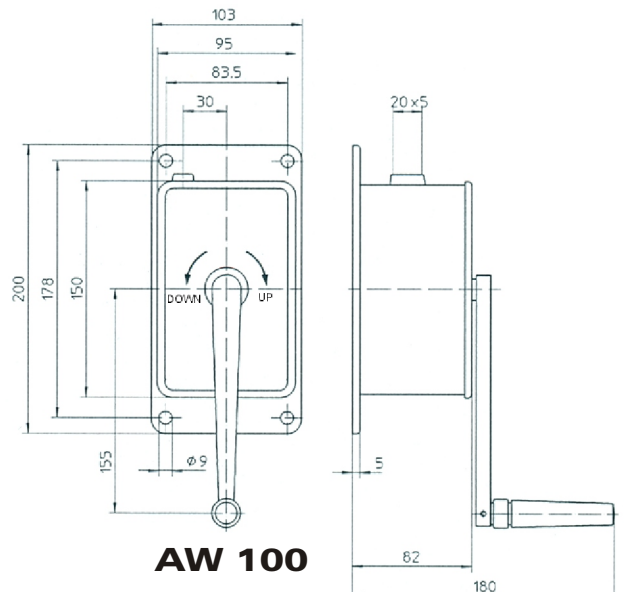

AW 100

SPECIFICATIONS		
Model	AW 45	AW 100
Article No.	030241000	030241001
Lifting Capacity 1st Layer	100 lb	220 lb
	45 kg	100 kg
Wire Rope Size	Capacity	
1/16"	54 ft	72 ft
3/32"	30 ft	40 ft
1/8"	18 ft	24 ft
5/32"	-	15 ft
2 mm	12.0 m	16.0 m
3 mm	6.0 m	8.0 m
4 mm	-	4.5 m
Average Lift per Crank	4.0"	1.6"
	100 mm	40 mm
Gear Ratio	1:1	3:1
Average Crank Force	18 lb	13 lb
	8 kg	6 kg
Net Shipping Weight	2.2 lb	4.6 lb
	1.0 kg	2.1 kg